

PicoFlow

Continuous flow measurement
at low solid/air ratios

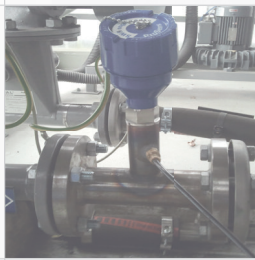
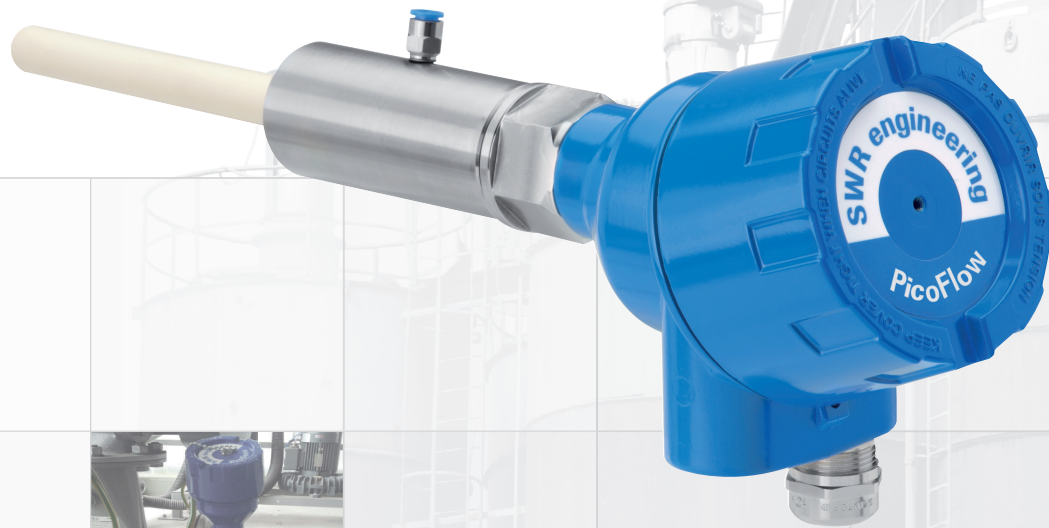

Use

PicoFlow was specially developed for measuring powder flows in transport lines with very low material concentrations. PicoFlow is particularly good in pneumatic applications but will also work reliably in free-fall applications with drop speeds of at least 2 m/s.

The measuring system delivers absolute measurements (after calibration) in g/h or kg/h. A special air purging system is also available as an option. This is used for materials which tend to bake onto surfaces.

PicoFlow is used for the following:

- In pneumatic applications for material flow rates of up to 100 kg/h (depending on application)
- In free-fall with a drop speed of at least 2 m/s (approx. 25 cm drop height)
- In cases where dust measuring instruments cannot cope and flow rate measuring instruments are over-specified

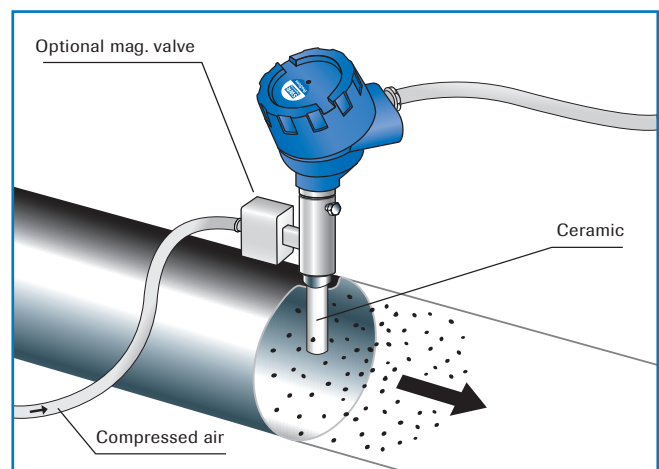
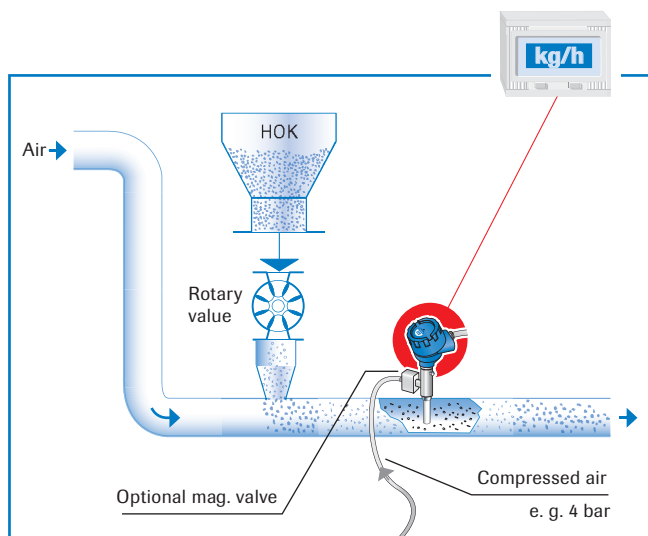

Function

The measuring principle of the PicoFlow is based on the electrodynamic measuring effect. A ceramic coating on the very short antenna prevents sensor wear. Specially developed hardware and software allows the measurements to be linearised.

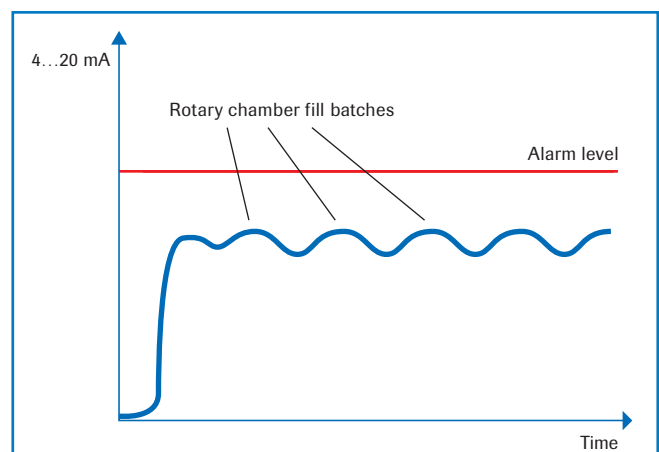

System

A complete measuring point consists of the following components:

- Weld-on socket with air purge connection
- PicoFlow sensor with ceramic coating
- PME 100 transmitter

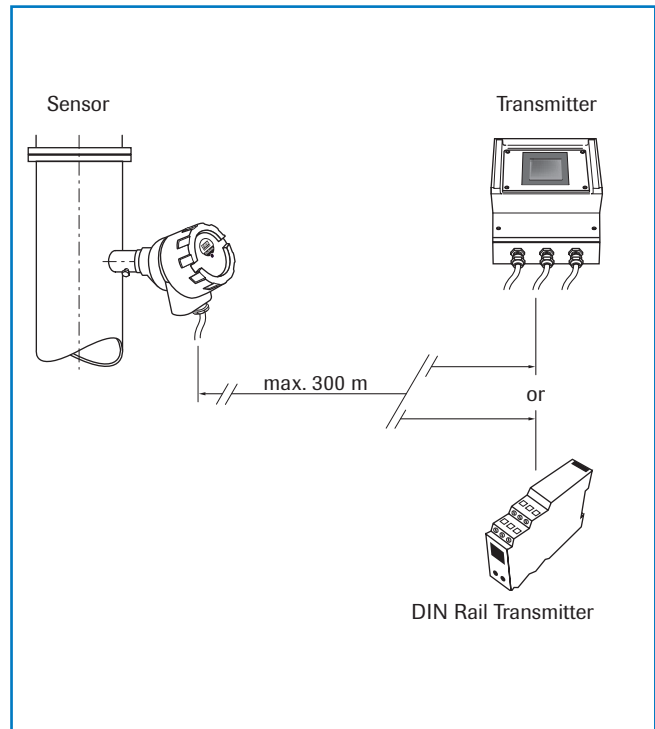

Mounting and installation

The PicoFlow can be installed in metallic ducts and pipelines.

It should be installed as far as possible away from curves and other fittings such as valves and slides.

The distance between the sensor rod and fittings in the duct should be at least three times the duct diameter in every flow direction.

Non-metallic ducts must be cased with a metal sleeve, a metal foil or a tight-mesh metal grille over a length of at least five times the duct diameter.

After deciding the installation location, drill a hole in the duct wall where the supplied weld-on socket can be welded perpendicular to the pipe. Then screw the sensor rod into the socket using the screw-in thread.

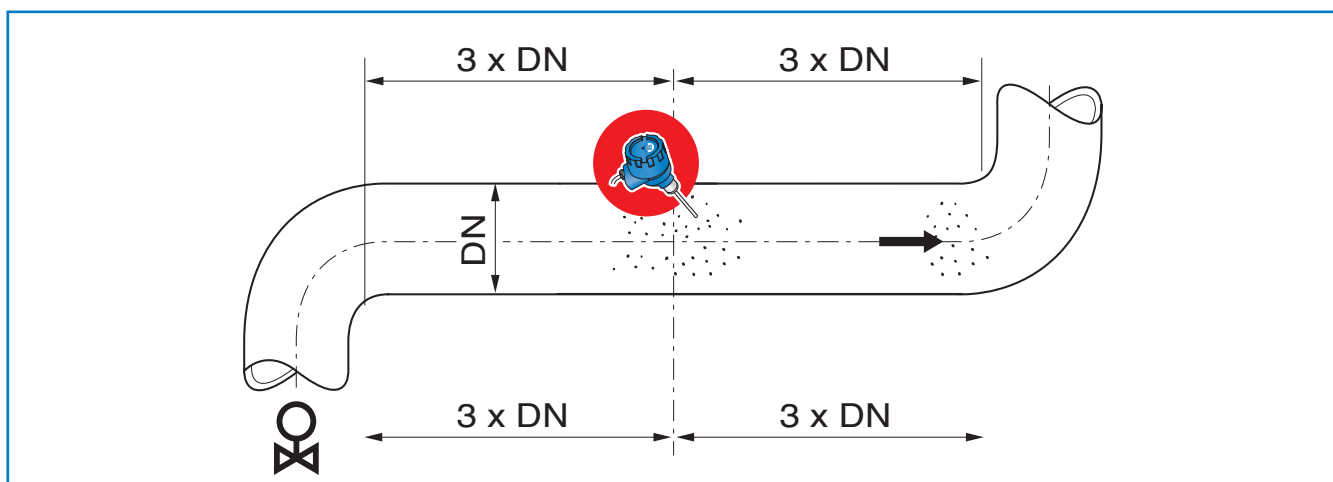

Technical data

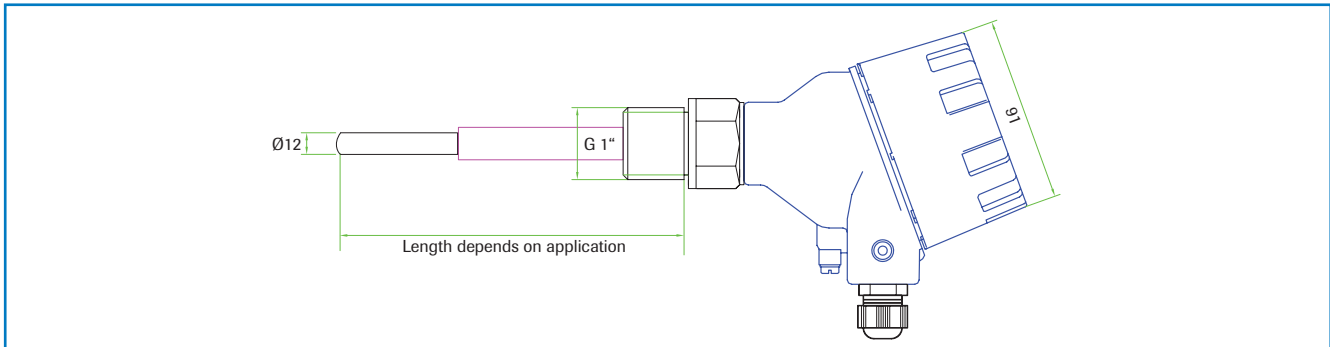

Sensor	
Measurement range	From 100 g/h to 100 kg/h (depends on application)
Process temperature	Standard: 150 °C; Optional: max. 500 °C
Pressure	Max. 2 bar (optional: up to 25 bar)
Flow velocity	Min. 2 m/sec
Humidity	60 % RH or less (non-condensing)
Measurement principle	Electrodynamics
Ambient temperature	-20 ... +60 °C
Sensor rod	Material: Stainless steel, AL2O3 ceramic 99.7 %; length: depends on application
Housing material	Aluminium
Protection type	IP 66; ATEX: Cat. 1/2 GD
Electrical connection	Connection chamber DIN M 20
Switch output measurement alarm	Relay with switchover contact Max. 250 V/AC, 1A Not on EX devices Cat. 1 and 2
Weight	Approx. 1.5 kg

Transmitter (DIN rail)	
Power supply	24 ± 10 % V DC
Power consumption	20 W / 24 V
Protection type	IP 40 to EN 60529
Ambient operating temperature	-10 ... +45 °C
Dimensions	23 x 90 x 118 (W x H x D)
Weight	Approx. 172 g
Connection terminals cable cross-section	0.2 - 2.5 mm ² [AWG 24-14]
Current output	4 ... 20 mA, load < 500 Ω
Switch output measurement alarm	Relay output, either NC (break contact) or NO (make contact) - max. 250 V AC, 1 A
Switch output error alarm	
Field bus communication	ModBus RTU (RS 485)
Data backup	Flash memory

Transmitter (field housing)	
Power supply	110/230 V, 50 Hz (optional 24 V DC)
Power consumption	20 W / 24 VA
Protection type	IP 65 to EN 60 529/10.91
Ambient operating temperature	- 10 ... + 45 °C
Dimensions	258 x 237 x 174 (W x H x D)
Weight	Approx. 2.5 kg
Interface	RS 485 / RS 232 C (ModBus)
Cable screw connectors	3 x M16 (4.5 - 10 mm Ø)
Connection terminals cable cross-section	0.2-2.5 mm ² [AWG 24-14]
Current output	4 ... 20 mA (0 ... 20 mA), load < 500 Ω
Switch output measurement alarm	Relay with switchover contact max. 250 V AC, 1 A
Data backup	Flash memory
Pulse output	Open collector - max. 30 V, 20 mA



certified according to
ATEX

