

Piezoelectric Accelerometer Type CE 281

FEATURES

- ▶ Industrial vibration monitoring
- ▶ Integrally attached electronics
- ▶ Long distance signal transmission
- ▶ Certified for use in explosive atmospheres
- ▶ 2-wire signal transmission with current modulation

CHARACTERISTICS

- ▶ Frequency response
3 Hz to 7000 Hz
- ▶ Sensitivity
10 μ A/g
- ▶ Temperature
Accelerometer : -55°C to +260°C (operational)
Electronics : -55°C to +100°C (operational)

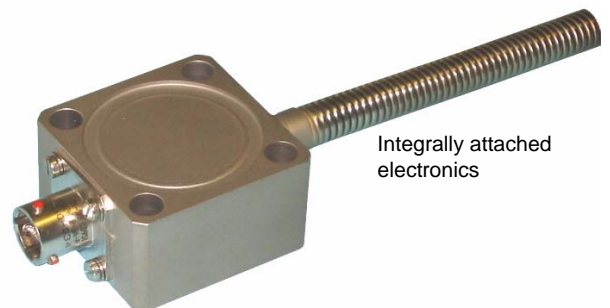

DESCRIPTION

The CE 281 accelerometer is equipped with a centre mounted symmetrical shear mode polycrystalline element. The attached electronics eliminates the need for a charge amplifier. The integral cable between the transducer and the electronics casing is protected by a hermetic stainless steel, flexible tube.

The electronics provides a charge-to-current conversion, and the modulated current output signal allows the use of a 2-wire cable for trouble-free transmission over long distances. The system is fully protected against cooling fluids, lubricants, water, steam etc.

SPECIFICATIONS

ELECTRICAL

Input power requirements	: 12...28 V _{DC} , zero signal current 3...8 mA
Signal transmission	: 2-wire system with modulated current output
Signal processing	: Galvanic separation unit

OPERATING

(at +23°C ±5°C)

Sensitivity (at 120 Hz)	: 10 µA/g ±5%
Dynamic measuring range (random)	: 0.0001 g to 200 g peak
Overload capacity (spikes)	: Up to 2000 g peak
Resonant frequency (mounted)	: 25 kHz nominal
Transverse sensitivity	: ≤ 3% (when measured at 15 Hz and 5 g)
Linearity	: ≤ 1% over dynamic measuring range
Frequency response	: ±5% between 3 Hz and 7000 Hz

ENVIRONMENTAL

Temperature range	
• <i>Transducer and BOA cable</i>	: -55°C to +260°C (survival: -70°C to +280°C for maximum 15 min)
• <i>Electronics</i>	: -55°C to +100°C
Shock acceleration	
• <i>Transducer</i>	: 2000 g peak (half sine 1 ms)
• <i>Electronics</i>	: 500 g peak
Explosive atmosphere	: Available in Ex i version for use in hazardous locations according to:
• <i>EC type examination certificate</i>	: KEMA 04 ATEX 1055 II 1 G (Zones 0, 1, 2) EEx ia IIC T4 to T6



For specific parameters of the mode of protection concerned and special conditions for safe use, please refer to the "EC type examination certificate" that is available from Vibro-Meter SA on demand.

• <i>cCSAus standard</i>	: Certificate No. 1514310, Class I, Div. 1, Groups A, B, C and D, Ex ia
Corrosion, humidity	: Accelerometer casing made from 1.4441 (AISI 316LVM), stainless steel, hermetically welded. Withstands 100% RH, impervious to and unaffected by water, steam or oil.
Base strain sensitivity	: 0.0025 g/µε nominal

MOUNTING

• <i>Transducer</i>	: 3 Allen screws M4 x 16, with 3 spring lock washers M4. Fastening torque 4.5 Nm
---------------------	--

- *Attached electronics* : 4 Allen screws M6 x 35, with 4 spring lock washers M6. Fastening torque 15 Nm

CONNECTIONS

- *Bayonet connector* : Type MS 3112 E8-3P (stainless steel)
- *Threaded connector* : Type MIL-C-83723, series III T, size 0803N (stainless steel)

CALIBRATION

: Dynamic calibration at factory at 5 g peak and 120 Hz (+23°C).
No subsequent calibration necessary.

MECHANICAL DRAWING

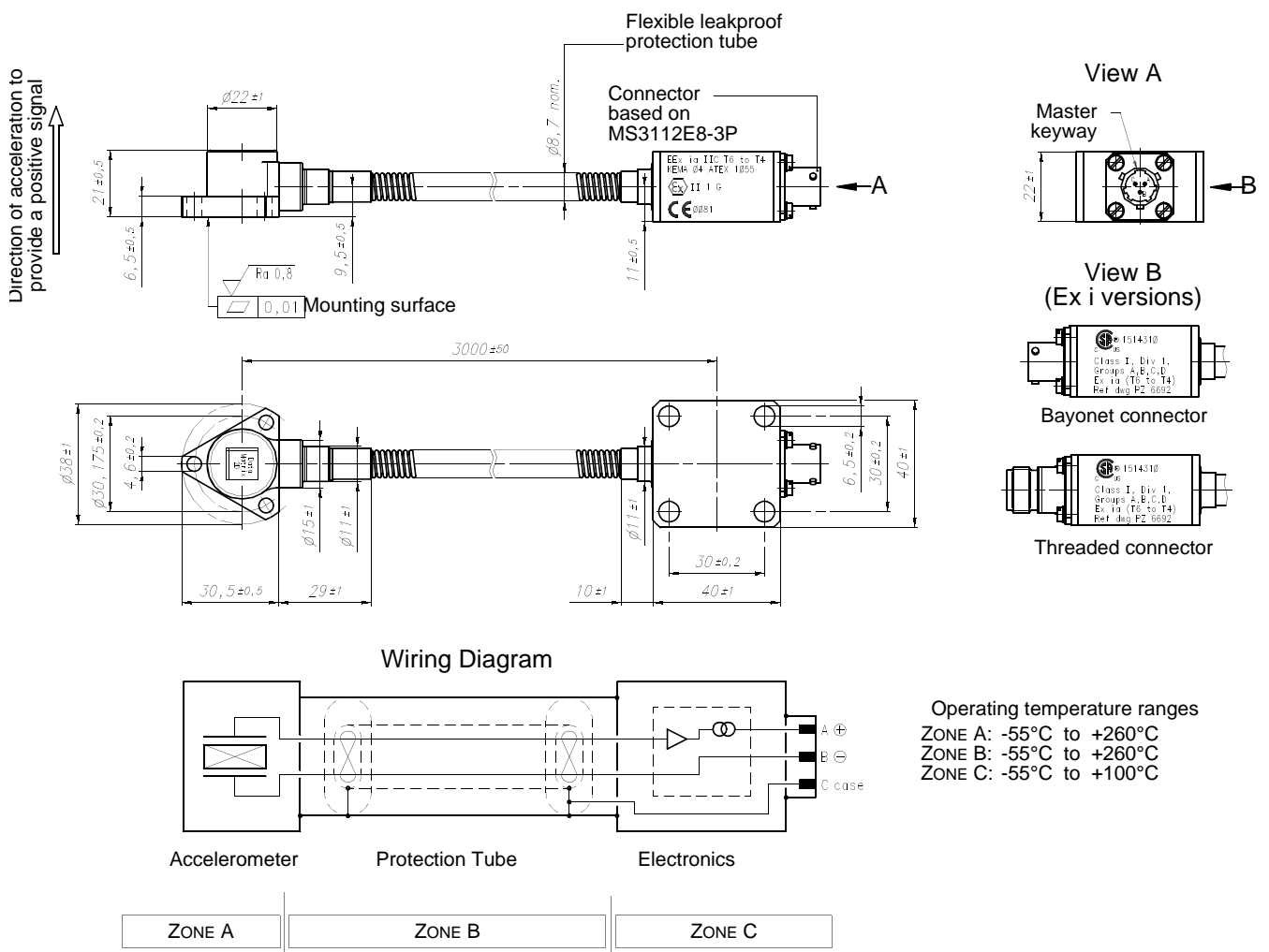

ORDERING INFORMATION

To order please specify :

Type	Designation		Ordering Number
CE 281	Piezoelectric Accelerometer	Standard	444-281-000-01
		Exi with bayonet connector	444-281-000-11
		Exi with threaded connector	444-281-000-21



In this publication, a dot (.) is used as the decimal separator and thousands are separated by spaces. Example : 12 345.678 90. Although care has been taken to assure the accuracy of the data presented in this publication, we do not assume liability for errors or omissions. We reserve the right to alter any part of this publication without prior notice.

Sales offices

Vibro-Meter has offices in more than 30 countries. For a complete list, please visit our website.

Your local agent

Head office

Vibro-Meter SA
Rte de Moncor 4
P.O. Box
CH-1701 Fribourg
Switzerland

Tel: +41 26 407 11 11
Fax: +41 26 407 13 01

www.vibro-meter.com

