

Datasheet

ME12**Remotely Configurable Digital Pressure Transmitter**

Application

Pressure transmitter with a ceramic measuring cell for measuring positive and negative pressures.

- Gauge pressure range from -1 ... 0 bar to 0 ... 60 bar.
- Absolute pressure range from 0 ... 1 bar to 0 ... 16 bar

Pressure transmitters from this series are suitable for a wide variety of measuring tasks in the fields of:

- Process engineering
- Process technology
- Environmental engineering

Construction and mode of operation

The pressure being measured acts directly on the ceramic diaphragm, causing it to distort. That in turn alters the resistance of the strain gauge on the rear of the diaphragm in proportion to the level of distortion.

Electronics in the pressure transmitter housing convert the change in resistance into standard electrical signals.



Key features

- Configurable
- Robust housing design
- High accuracy
- Low hysteresis

Parameterisation

The device is supplied as defined in the ordering code.

Nevertheless, to optimise performance in line with prevailing process conditions it is also possible to configure the pressure transmitter on-site via the connection cables. To do so you will require a PC as well as the programming adapter EU13, available as an accessory.

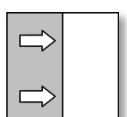

Technical data

| | | | | | | | | | | | | | | | | | | | | |
|--|--------|-----------|-----------|---------|---------|---------|----------|----------|--|---------|-------|---------|---------|-------|-------|--------|--------|--------|--------|--------|
| Relative pressure measuring range [bar] | -1...0 | -1...+0.6 | -1...+1.5 | -1...+3 | -1...+5 | -1...+9 | -1...+15 | -1...+24 | | 0...0.6 | 0...1 | 0...1.6 | 0...2.5 | 0...4 | 0...6 | 0...10 | 0...16 | 0...25 | 0...40 | 0...60 |
| Overload pressure safety [bar] | 4 | 4 | 4 | 10 | 20 | 40 | 40 | 100 | | 4 | 4 | 4 | 10 | 12 | 20 | 40 | 40 | 100 | 100 | 200 |

| | | | | | | | | | | | | | | | | | | | | |
|--|--|--|--|--|--|--|--|--|--|--|-------|---------|---------|-------|-------|--------|--------|--|--|--|
| Absolute pressure measuring range [bar] | | | | | | | | | | | 0...1 | 0...1.6 | 0...2.5 | 0...4 | 0...6 | 0...10 | 0...16 | | | |
| Overload pressure safety [bar] | | | | | | | | | | | 2 | 2 | 5 | 5 | 10 | 20 | 20 | | | |

General:

- Linearity < 1.0 % FS (optionally < 0.5 %FS)
- Hysteresis < 0.5 % FS
- Permissible ambient temperature -10 °C...+70 °C
- Permissible continuous media temperature -10 °C...+85 °C
- Pressure connection See order code
- Electrical connection Line socket DIN EN 175 301-803-A or M12 plug connector DIN EN 61076-2-101
- Protection class IP 65 according to DIN EN 60 529
- Materials in contact with media Chromium nickel steel 1.4404, ceramic Al₂O₃, see order code for seal
- Casing materials Chromium nickel steel 1.4305

Electrical Data:

| | 2-wire current output | 3-wire voltage output | 3-wire current output |
|---|-------------------------------|--------------------------------------|--|
| Rated voltage | 24 VDC | 24 VAC/DC | 24 VAC/DC |
| Permissible supply voltage U _b | 6...30 VDC | 15...30 VAC/DC | 15...30 VAC/DC |
| Output signal | 4...20 mA | 0...10 VDC | 0...20 mA 4...20 mA |
| Limit of the output signal | ca. 26 mA | ca. 10.5 VDC | ca. 23 mA |
| Apparent ohmic resistance | (U _b - 6V) / 0.02A | ≥ 5 kΩ ab 15 VDC ≥ 2 kΩ ab 20 VDC | [(U _b - 10V) / 0.02A] + 300 Ω |
| Zero-point temperature drift | 0.07 % FS/K | 0.07 % FS/K | 0.07 % FS/K |
| Measuring range temperature drift | 0.05 % FS/K | 0.05 % FS/K | 0.05 % FS/K |

Configuration:

- Characteristic curve inversion Increasing / decreasing
- Attenuation 0...200 s
- Adjustable signal limits Uppers current limit 3.5...22.5 mA
Lower current limit 3.5...22.5 mA
Error signal 3.5...22.5 mA
- Offset correction +/-25 %FS
- Span correction +/-25 %FS

Dimensioned drawings

Possible pressure and electrical connections:

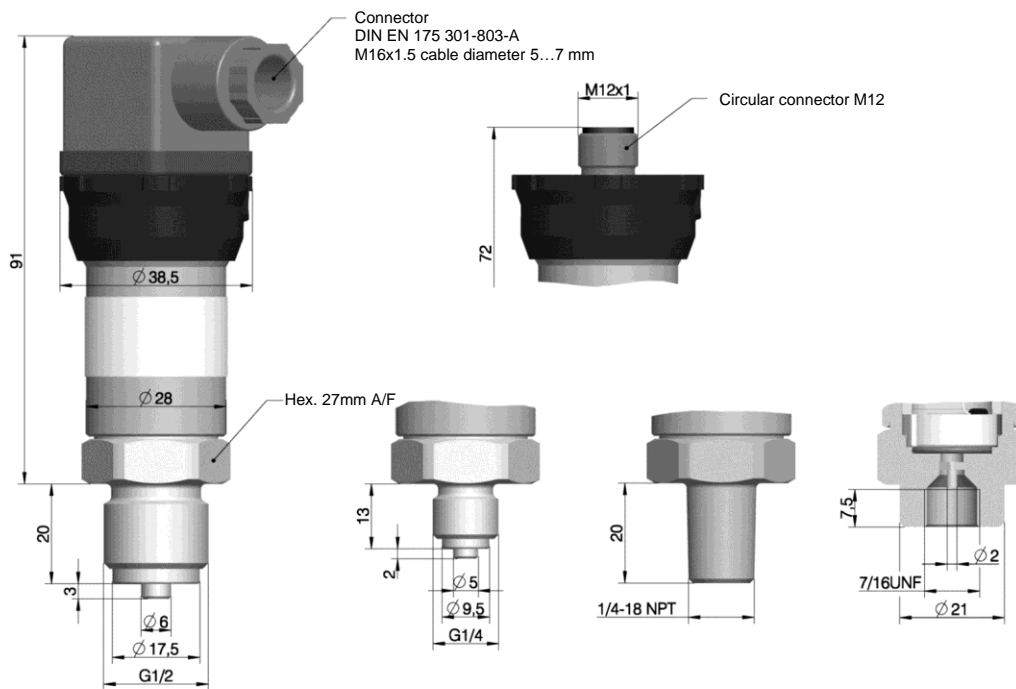

Code **87**

85

88

S1

Model with near flush-mounted front sensor:

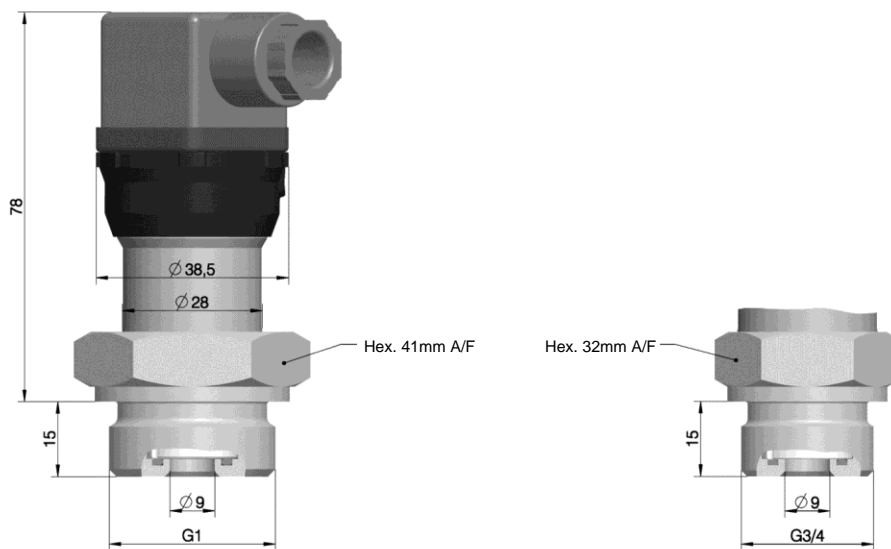

Code **A3**

A8

