



**Features**

- True RMS or calculated peak output
- Corrosion resistant
- Hermetic seal
- ESD protection
- Overload protection
- Reverse wiring protection

**Benefits**

- Choice of output: RMS or peak, permits you to choose the sensor that best fits your industrial requirements
- 24/7 output of overall machine vibration for trending in PLC
- Helps guide maintenance in prioritizing need for service
- Alerts users of changing machine condition

The 4-20 mA output of the PC420A Series is proportional to acceleration vibration. An output of 4 mA indicates a level of 0 g or no vibration present. A full-scale reading of 20 mA indicates that the maximum range (RMS or peak) of vibration is present.

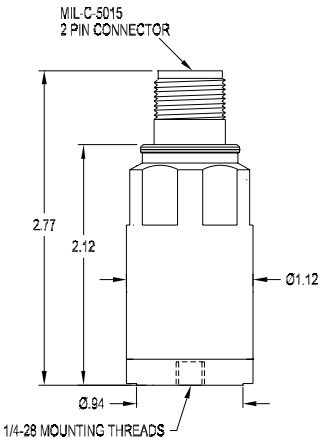

**Model PC420A Series - RMS and peak Acceleration loop powered sensors (LPS™)**

**Output, 4-20 mA**

Full scale, 20 mA (±5%).....	see table 1 on back
Frequency response:	
±10% .....	10 Hz - 1.0 kHz
±3 dB .....	1 Hz - 2.0 kHz
Repeatability .....	±2%
Transverse sensitivity, max.....	5%

**Electrical**

Power requirements (two wire loop power):	
Voltage at PC420 Series sensor terminals.....	10 VDC min, 30 VDC max
Loop resistance at 24 VDC, maximum.....	700Ω
Turn on time, 4-20 mA loop .....	< 30 seconds
Grounding.....	case isolated, internally shielded

**Environmental**

Operating temperature range <sup>1</sup> .....	-40 to 105°C
Vibration limit .....	250 g peak
Shock limit .....	2,500 g peak
Sealing .....	hermetic

**Physical**

Sensing element design .....	PZT ceramic / shear
Weight .....	160 grams
Case material.....	stainless steel
Mounting .....	1/4 - 28 tapped hole
Output connector .....	2 pin, MIL-C-5015 style
Mating connector .....	R6 type
Recommended cabling .....	J9T2A

Connector pin	Function
Shell	ground
A	loop positive (+)
B	loop negative (-)

Notes: <sup>1</sup> 105°C operating temperature applies to units shipped after July 1, 2009, and with serial numbers greater than 50000.

Accessories supplied: SF6 mounting stud (International customers specify mounting requirements); calibration data (level 2).



**Table 1: PC420Ax-yy model number selection**

x (4-20 mA output type)	yy (4-20 mA full scale)
R = RMS output, acceleration	05 = 5 g
P = Calculated peak output, acceleration	10 = 10 g
	20 = 20 g
	50 = 50 g

Notes: <sup>1</sup> Maximum loop resistance [R<sub>L</sub>] can be calculated by:

$$R_L \text{ (max resistance)} = \frac{V_{DC \text{ power}} - 10 \text{ V}}{20 \text{ mA}}$$

DC Supply Voltage	R <sub>L</sub> (max resistance) <sup>2</sup>	R <sub>L</sub> (minimum wattage capability) <sup>3</sup>
12 VDC	100Ω	1/8 Watt
20 VDC	500Ω	1/4 Watt
24 VDC	700Ω	1/2 Watt
26 VDC	800Ω	1/2 Watt
30 VDC	1.0kΩ	1/2 Watt

<sup>2</sup> Lower resistance is allowed, greater than 100Ω recommended.

<sup>3</sup> Minimum R<sub>L</sub> wattage determined by: (0.0004 x R<sub>L</sub>).

Typical circuit

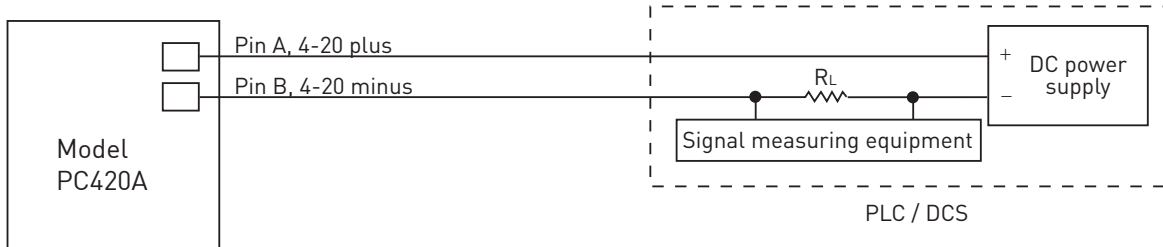

**Wilcoxon Research Inc**  
 20511 Seneca Meadows Parkway  
 Germantown, MD 20876  
 USA

Tel: 301 330 8811  
 Fax: 301 330 8873  
 Email: wilcoxon@meggitt.com

www.meggitt.com

**MEGGITT**  
 smart engineering for  
 extreme environments



**Features**

- True peak output
- Corrosion resistant
- Hermetic seal
- ESD protection
- Overload protection
- Reverse wiring protection

**Benefits**

- 24/7 output of true peak acceleration machine vibration for trending in PLC
- True peak is useful for detecting looseness, valves, rod knock and piston slap on reciprocating machinery
- Helps guide maintenance in prioritizing need for service
- Alerts users of changing machine condition

The 4-20 mA output of the PC420ATP Series is proportional to true peak acceleration vibration. An output of 4 mA indicates a level of 0 g or no vibration present. A full-scale reading of 20 mA indicates that the maximum range of vibration is present.

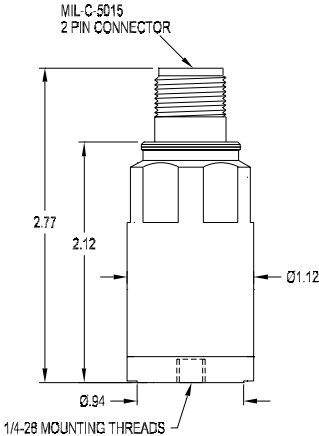

**Model PC420ATP Series - true peak Acceleration loop powered sensors (LPS™)**

**Output, 4-20 mA**

Full scale, 20 mA (±5%).....	see table 1 on back
Frequency response:	
±10% .....	10 Hz - 1.0 kHz
±3 dB .....	4 Hz - 2 kHz
Repeatability .....	±2%
Transverse sensitivity, max.....	5%

**Electrical**

Power requirements (two wire loop power):	
Voltage at PC420 Series sensor terminals.....	10 VDC min, 30 VDC max
Loop resistance <sup>1</sup> at 24 VDC, maximum .....	700Ω
Turn on time, 4-20 mA loop .....	< 30 seconds
Grounding.....	case isolated, internally shielded

**Environmental**

Temperature range .....	-40 to 85°C
Vibration limit .....	250 g peak
Shock limit .....	2,500 g peak
Sealing .....	hermetic

**Physical**

Sensing element design .....	PZT ceramic / shear
Weight .....	162 grams
Case material.....	stainless steel
Mounting .....	1/4 - 28 tapped hole
Output connector .....	2 pin, MIL-C-5015 style
Mating connector .....	R6 type
Recommended cabling .....	J9T2A

Connector pin	Function
Shell	ground
A	loop positive (+)
B	loop negative (-)

Accessories supplied: SF6 mounting stud (International customers specify mounting requirements); calibration data (level 2).



**Table 1: PC420ATP-yy model number selection**

yy (4-20 mA full scale)
05 = 5 g
10 = 10 g
20 = 20 g

Notes: <sup>1</sup> Maximum loop resistance [ $R_L$ ] can be calculated by:

$$R_L \text{ (max resistance)} = \frac{V_{DC \text{ power}} - 10 \text{ V}}{20 \text{ mA}}$$

DC Supply Voltage	$R_L$ (max resistance) <sup>2</sup>	$R_L$ (minimum wattage capability) <sup>3</sup>
12 VDC	100Ω	1/8 Watt
20 VDC	500Ω	1/4 Watt
24 VDC	700Ω	1/2 Watt
26 VDC	800Ω	1/2 Watt
30 VDC	1.0kΩ	1/2 Watt

<sup>2</sup> Lower resistance is allowed, greater than 10Ω recommended.

<sup>3</sup> Minimum  $R_L$  wattage determined by:  $(0.0004 \times R_L)$ .

Typical circuit

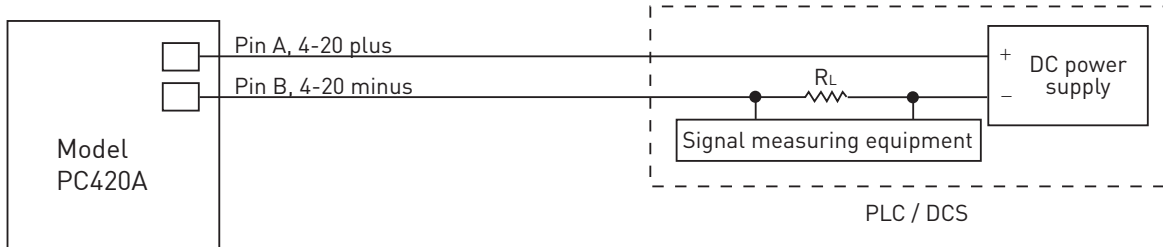

**Wilcoxon Research Inc**  
 20511 Seneca Meadows Parkway  
 Germantown, MD 20876  
 USA

Tel: 301 330 8811  
 Fax: 301 330 8873  
 Email: wilcoxon@meggitt.com

www.meggitt.com

**MEGGITT**  
 smart engineering for  
 extreme environments