

Features

- Peak equivalent, true RMS or true peak output
- Optional dynamic signal output
- Corrosion resistant
- Hermetic seal
- ESD protection
- Overload protection
- Reverse wiring protection

Benefits

- Choice of output: RMS, equivalent peak, and true peak; permits you to choose the sensor that best fits your industrial requirements
- Provides continuous trending of overall machine vibration
- Can help guide maintenance
- Dynamic signal output allows spectral vibration measurements using a single sensor

The 4-20 mA output of the PC421 Series is proportional to vibration. An output of 4 mA indicates a level of 0 ips or no vibration present for velocity output models and 0 g for acceleration output models. A full-scale reading of 20 mA indicates that the maximum range (RMS, Equivalent Peak or True Peak) of the chosen unit, acceleration of velocity, is present.

The dynamic signal output is an optional addition. Any of the base sensor models can also have dynamic signal output. Adding -DA to a model specifies a dynamic acceleration signal output (100 mV/g). Adding -DV to a model specifies a dynamic velocity signal output (100 mV/ips).

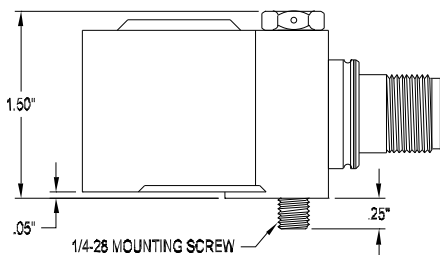
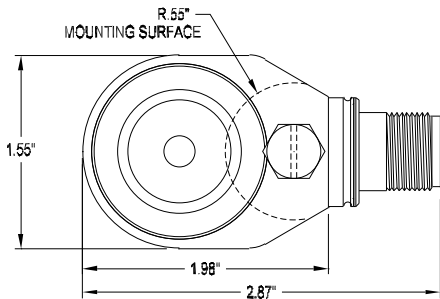

# Model PC421 Loop Powered Sensor (LPS™) Side exit, 4-20mA

## Output, 4-20 mA

Full scale, 20 mA (±5%) .....	see Table 1 on back
Frequency response:	
±10% .....	10 Hz - 1.0 kHz
±3 dB .....	4 Hz - 2 kHz
Repeatability .....	±2%
Transverse sensitivity, max .....	5%

## Output, dynamic

	PC421xxx-yy-DA	PC421xxx-yy-DV
Sensitivity (±10%) .....	100 mV/g	100 mV/ ips
Full scale .....	20g, peak	1.5 ips @ 1kHz
Frequency response:		
±3 dB .....	2.5 Hz - 10 kHz	2.5 Hz - 2.5 kHz
Amplitude nonlinearity, maximum .....	1%	
Resonant frequency, mounted, nominal .....	21 kHz	
Transverse sensitivity, max .....	5%	

## Electrical

Power requirements (Two wire loop power):

Voltage (between pins A & B) .....	10 VDC min, 30 VDC max
Loop resistance <sup>1</sup> at 24 VDC, maximum .....	700Ω
Turn on time, 4-20 mA loop .....	30 seconds
Grounding .....	case isolated, internally shielded

## Environmental

Temperature range .....	-40 to 85°C
Vibration limit .....	250 g peak
Shock limit .....	2,500 g peak
Sealing .....	hermetic

## Physical

Sensing element design .....	PZT ceramic / shear	
Weight .....	320 grams	
Case material .....	316L stainless steel	
Mounting .....	1/4 - 28 captive bolt	
	PC421xxx-yy	PC425xxx-yy-Dz
Outut connector, MIL-C-5015 style .....	2 pin	3 pin
Mating connector .....	R6 type	R6G type
Recommended cabling .....	J9T2A	J9T3A

## Connections

PC421xxx-yy	PC421xxx-yy-Dz	
Connector pin	Connector pin	Function
shell	shell	ground
A	A	loop positive (+)
B	B	loop negative (-)
NA	C	dynamic signal

See back for notes.

Notes: <sup>1</sup> maximum loop resistance (RL) can be calculated by:

$$RL \text{ (max. resistance)} = \frac{V_{DC \text{ power}} - 10 \text{ V}}{20 \text{ mA}}$$

DC Supply Voltage	RL (max resistance) <sup>2</sup>	RL (minimum wattage capability) <sup>3</sup>
12 VDC	100Ω	1/8 Watt
20 VDC	500Ω	1/4 Watt
24 VDC	700Ω	1/2 Watt
26 VDC	800Ω	1/2 Watt
30 VDC	1.0kΩ	1/2 Watt

<sup>2</sup> Lower resistance is allowed, greater than 10Ω recommended

<sup>3</sup> Minimum RL wattage determined by: (0.0004 x RL)

xxx (4-20 mA output type)	-yy (full scale)	-Dz (dynamic output) <sup>A</sup>
AR = acceleration, RMS AP = acceleration, equivalent peak <sup>B</sup> ATP = acceleration, true peak <sup>C</sup>	-05 = 5 g (49 m/sec <sup>2</sup> ) -10 = 10 g (98 m/sec <sup>2</sup> ) -20 = 20 g (196 m/sec <sup>2</sup> )	-DA = dynamic acceleration 100 mV/g (10.2 mV/ m/sec <sup>2</sup> ) -DV = dynamic velocity 100 mV/ips (3.94 mV/ mm/sec)
VR = velocity, RMS VP = velocity, equivalent peak <sup>B</sup> VTP = velocity, true peak <sup>C</sup>	-05 = 0.5 i.p.s. (12.8 mm/sec) -10 = 1.0 i.p.s. (25.4 mm/sec) -20 = 2.0 i.p.s. (50.8 mm/sec) -30 = 3.0 i.p.s. (76.2 mm/sec) -50 = 5.0 i.p.s. (127 mm/sec)	-DA = dynamic acceleration 100 mV/g (10.2 mV/ m/sec <sup>2</sup> ) -DV = dynamic velocity 100 mV/ips (3.94 mV/ mm/sec)

Table 1: PC421xxx-yy-Dz Model Number Selection

<sup>A</sup> **Dynamic output is an option on all models.** If dynamic output option is not desired, do not add -DA or -DV to the model number.

<sup>B</sup> **Equivalent peak** output is developed based on the true RMS value of vibration. For a pure sine wave, the equivalent peak output is 1.414 times the RMS value.

<sup>C</sup> **True peak** output is based on the actual measured peak value using the time waveform and is not based on the RMS calculation.

### PC421xxx-yy WIRING

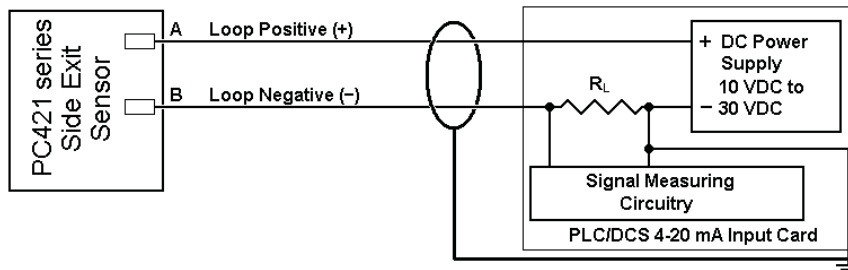

### PC421xxx-yy-Dz WIRING

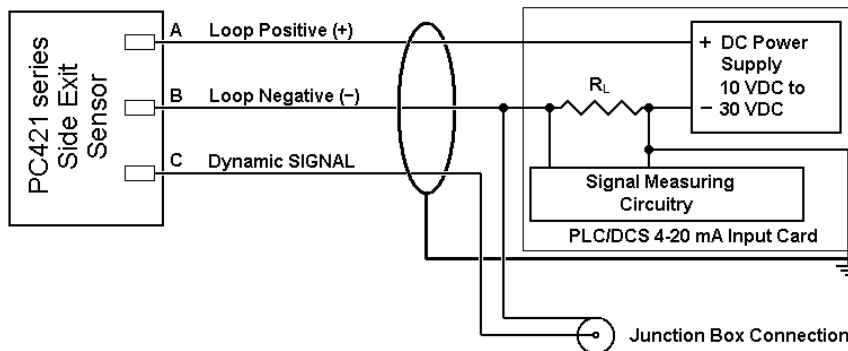

Wilcoxon Research Inc  
20511 Seneca Meadows Parkway  
Germantown, MD 20876  
USA

Tel: 301 330 8811  
Fax: 301 330 8873

Email: wilcoxon@meggitt.com

www.meggitt.com

**MEGGITT**  
smart engineering for  
extreme environments

All wire and cable used for installation of the PC421-series sensor should be shielded. Generally accepted instrumentation wiring practice considers the best way to ground the shield is to connect it at the measurement end of the cable. The shield should not be wired to ground at the sensor end of the cable. Wilcoxon R6W, R6GQAI, R6GQI and R6QI type connectors all leave the shield unconnected at the sensor end of the cable.