



Wilcoxon Research model PCC423 Side exit loop powered sensor (LPS™) with integral cable

Features

- Acceleration or velocity output units
- True root-mean-square (RMS) or calculated peak output
- Corrosion resistant
- Hermetic seal
- ESD, overload and reverse wiring protection
- Connector options: integral cable or (model PCC421) MIL-C-5015 2 pin or M12 4 pin

Benefits

- Choice of RMS or peak output allows you to choose the sensor that best fits your requirements
- Enables continuous trending of overall machine vibration
- Can help guide maintenance in prioritizing the need for service
- Helps notify of impending equipment failure

The 4-20 mA output of this sensor series is proportional to the overall vibration. An output of 4 mA indicates no vibration; a level of 0 ips for velocity output models; a level of 0 g for acceleration output models. A full-scale reading of 20 mA indicates that the maximum range (RMS or peak) of vibration is present.

Dynamic

Output, 4-20 mA.....	loop signal proportional to acceleration or velocity, see table 1
Full scale, 20 mA, ±5%.....	selectable, see table 1
Frequency response, 4-20 mA.....	see table 2
Repeatability.....	±2%
Transverse sensitivity, max.....	5.0%

Electrical

Power requirements (two wire loop power):	
Voltage at sensor terminals.....	12 - 30 VDC
Loop resistance (at 24 VDC), max.....	700 Ω
Turn on time, 4-20 mA loop	<30 seconds
Grounding	case isolated, internally shielded

Environmental

Temperature range.....	-40 to 105°C
Vibration limit.....	250 g peak
Shock limit.....	2,500 g peak
Sealing	hermetic

Physical

Sensing element design	PZT ceramic/shear
Weight.....	145 grams, exclusive of cable
Case material	stainless steel
Mounting	captive screw, 1/4-28 ¹
Output.....	J9T2A integral cable, 16 feet, shielded twisted pair ²

¹ M6 captive screw available as an option

² J10 cable is available as an option

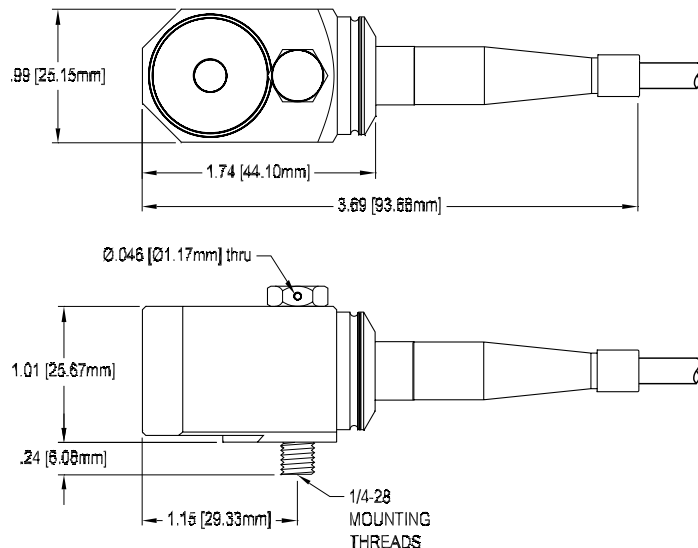



Table 1 - Part number configuration guide		
Part number	PCC423-xx-yy-C	
Output type		
xx	AR	Acceleration - RMS
	AP	Acceleration - peak
	VR	Velocity - RMS
	VP	Velocity - peak
Full scale		
yy	05	5.0 g (acceleration output)
		0.5 ips (velocity output)
	10	10 g (acceleration output)
		1.0 ips (velocity output)
	20	20 g (acceleration output)
2.0 ips (velocity output)		
50	50 ips (velocity output)	
Output		
C	J9T2A	Shielded, twisted pair cable, high temp
	J10	Shielded, twisted pair cable, general

Table 2 - PCC423 frequency response		
Acceleration	+/- 10%	10 - 1k Hz
	+/- 3 dB	1 - 2k Hz
Velocity	+/- 10%	10 - 1k Hz
	+/- 3 dB	3.5 - 2k Hz

Notes: (1) maximum loop resistance (RL) can be calculated by:

$$RL \text{ (max. resistance)} = \frac{V_{DC \text{ power}} - 10 \text{ V}}{20 \text{ mA}}$$

DC Supply Voltage	RL (max resistance) ²	RL (minimum wattage capability) ³
12 VDC	100Ω	1/8 Watt
20 VDC	500Ω	1/4 Watt
24 VDC	700Ω	1/2 Watt
26 VDC	800Ω	1/2 Watt
30 VDC	1.0kΩ	1/2 Watt

(2) Lower resistance is allowed, greater than 10Ω recommended

(3) Minimum RL wattage determined by: (0.0004 x RL)

PCC423 J9T2A wiring diagram and pin out

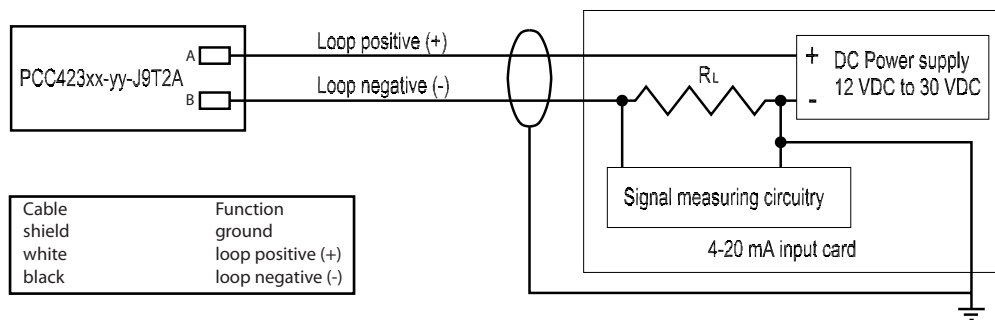

Meggitt Sensing Systems
 20511 Seneca Meadows Parkway
 Germantown, MD 20876
 USA

Tel: 301 330 8811
 Fax: 301 330 8873
 Email: wilcoxon@meggitt.com

www.meggitt.com

MEGGITT
 smart engineering for
 extreme environments