



TQ 422 and TQ 432 / EA 402 / IQS 450

Proximity measuring system

FEATURES

- » From the Vibro-Meter® product line
- » Designed for high-pressure applications
- » Non-contact measurement system based on eddy current principle
- » Certified for use in potentially explosive atmospheres
- » 1 m, 5 m and 10 m systems
- » Temperature compensated system
- » Voltage or current output with protection against short circuits
- » Frequency response:
DC to 20 kHz (-3 dB)
- » Measuring range:
2 or 4 mm
- » Temperature range:
-25 to +140°C



TQ 422 with
flexible hose



TQ 432 without
flexible hose



IQS 450



DESCRIPTION

This proximity system allows contactless measurement of the relative displacement of moving machine elements. The system is based around a TQ 422 or TQ 432 non-contact transducer and an IQS 450 signal conditioner. Together, these form a calibrated proximity system in which each component is interchangeable. The system outputs a voltage or current proportional to the distance between the transducer tip and the target, such as a machine shaft.

The TQ 422 and the TQ 432 are specially designed for high-pressure applications, with the transducer tip withstanding pressures of up to 100 bar. This makes them particularly suitable for measuring relative displacement or vibration on submerged pumps and various types of hydraulic turbines (for example, Kaplan and Francis). This sensor is also suitable for use when the region of the output of the sensor is cluttered.



Information contained in this document may be subject to Export Control Regulations of the European Union, USA or other countries. Each recipient of this document is responsible for ensuring that transfer or use of any information contained in this document complies with all relevant Export Control Regulations. ECN N/A.

DESCRIPTION *(continued)*

The active part of the transducer is a coil of wire that is moulded inside the tip of the device, made of PEEK (polyetheretherketone). The transducer body is made of stainless steel. The target material must, in all cases, be metallic.

The transducer body is available only with metric thread. Both the TQ 422 and the TQ 432 have an integral coaxial cable, terminated with a self-locking miniature coaxial connector. The TQ 432 version is intended for reverse-mount applications. Various cable lengths (integral and extension) can be ordered.

The IQS 450 signal conditioner contains a high-frequency modulator/demodulator that supplies a driving signal to the transducer. This generates the

necessary electromagnetic field used to measure the gap. The conditioner circuitry is made of high-quality components and is mounted in an aluminium extrusion.

The TQ 422 and the TQ 432 transducers can be matched with a single EA 402 extension cable to effectively lengthen the front-end. Optional housings, junction boxes and interconnection protectors are available for the mechanical and environmental protection of the connection between the integral and extension cables.

The proximity system can be powered by associated signal processing modules (for example, VM600 cards) or a rack power supply.

SPECIFICATIONS

Overall proximity system

Operation

Sensitivity

- *Ordering option B21* : 8 mV/μm (200 mV/mil)
- *Ordering option B22* : 2,5 μA/μm (62,5 μA/mil)
- *Ordering option B23* : 4 mV/μm (100 mV/mil)
- *Ordering option B24* : 1.25 μA/μm (31.2 μA/mil)

Linear measuring range (typical)

- *Ordering option B21* : 0 to 2.0 mm, corresponding to a -2.4 to -18.4 V output
- *Ordering option B22* : 0 to 2.0 mm, corresponding to a -15.5 to -20.5 mA output
- *Ordering option B23* : 0 to 4.0 mm, corresponding to a -2.4 to -18.4 V output
- *Ordering option B24* : 0 to 4.0 mm, corresponding to a -15.5 to -20.5 mA output

Linearity : See Performance curves on page 4

Frequency response : DC to 20 kHz (-3 dB)

Interchangeability of elements : All components in system are interchangeable

Environmental – explosive atmospheres

Available in Ex approved versions for use in hazardous locations

| Type of protection Ex i: intrinsic safety (ordering option A2) | | |
|---|----------------------------------|--|
| Europe | EC type examination certificate | LCIE 11 ATEX 3091 X II 1G (Zones 0, 1, 2) Ex ia IIC T6 ... T3 Ga |
| International | IECEx certificate of conformity | IECEx LCI 11.0061X Ex ia IIC T6 ... T3 Ga |
| North America | cCSAus certificate of compliance | 1514309 Class I, Divisions 1 and 2, Groups A, B, C and D Ex ia |

 **For specific parameters of the mode of protection concerned and special conditions for safe use, please refer to the Ex certificates that are available from Meggitt SA on demand.**

SPECIFICATIONS (continued)

| Type of protection Ex nA: non-sparking (ordering option A3) | | |
|---|--|--|
| Europe | Voluntary type examination certificate | LCIE 11 ATEX 1010 X II 3G (Zone 2) Ex nA II T6 ... T3 Gc |
| International | IECEX certificate of conformity | IECEX LCI 11.0063X Ex nA II T6 ... T3 Gc |
| North America | cCSAus certificate of compliance | 1514309 Class I, Division 2, Groups A, B, C, D |

 **When using protection mode 'nA' (non-sparking), the user shall ensure that the signal conditioner is installed in an enclosure that ensures a protection rating of at least IP54 (or equivalent).**

 **For specific parameters of the mode of protection concerned and special conditions for safe use, please refer to the Ex certificates that are available from Meggitt SA on demand.**

System calibration

Calibration temperature : +23°C ±5°C
Target material : VCL 140 steel (1.7225)

Note: If special calibration is required, please define the alloy precisely or supply a sample of alloy (min. Ø50 mm / 1 cm thick) according to Meggitt Sensing Systems' drawing number PZ 7009/1.

Total system length

The total system length (TSL) is the sum of the length of the TQ 4xx transducer's integral cable and the length of the EA 40x extension cable. The supported TSLs can be obtained from different combinations of cables.

Total system lengths

- 1 m : 1.0 m integral cable with no extension cable
- 5 m : 1.0 m integral cable + 4.0 m extension cable
5.0 m integral cable with no extension cable
- 10 m : 1.0 m integral cable + 9.0 m extension cable
5.0 m integral cable + 5.0 m extension cable
10.0 m integral cable with no extension cable

The combination of cables selected for a particular total system length depends on the application. For example, to obtain the optimum location for the separation between the integral and extension cables or to eliminate the requirement for an extension cable.

Total system length trimming

Due to the characteristics of the coaxial cable, an "electrical trimming" of the nominal length of extension cables is necessary to optimize the system performance and the transducer interchangeability.

TSL for a 1 m measuring chain : 0.9 m minimum
TSL for a 5 m measuring chain : 4.4 m minimum
TSL for a 10 m measuring chain : 8.8 m minimum

SPECIFICATIONS (continued)

Performance curves for TQ 422 and TQ 432 with IQS 450

Typical gap error (μm)
(Referenced to 4 mV/ μm
(1.25 $\mu\text{A}/\mu\text{m}$) line)

Typical sensitivity error
(Referenced to 4 mV/ μm
(1.25 $\mu\text{A}/\mu\text{m}$))

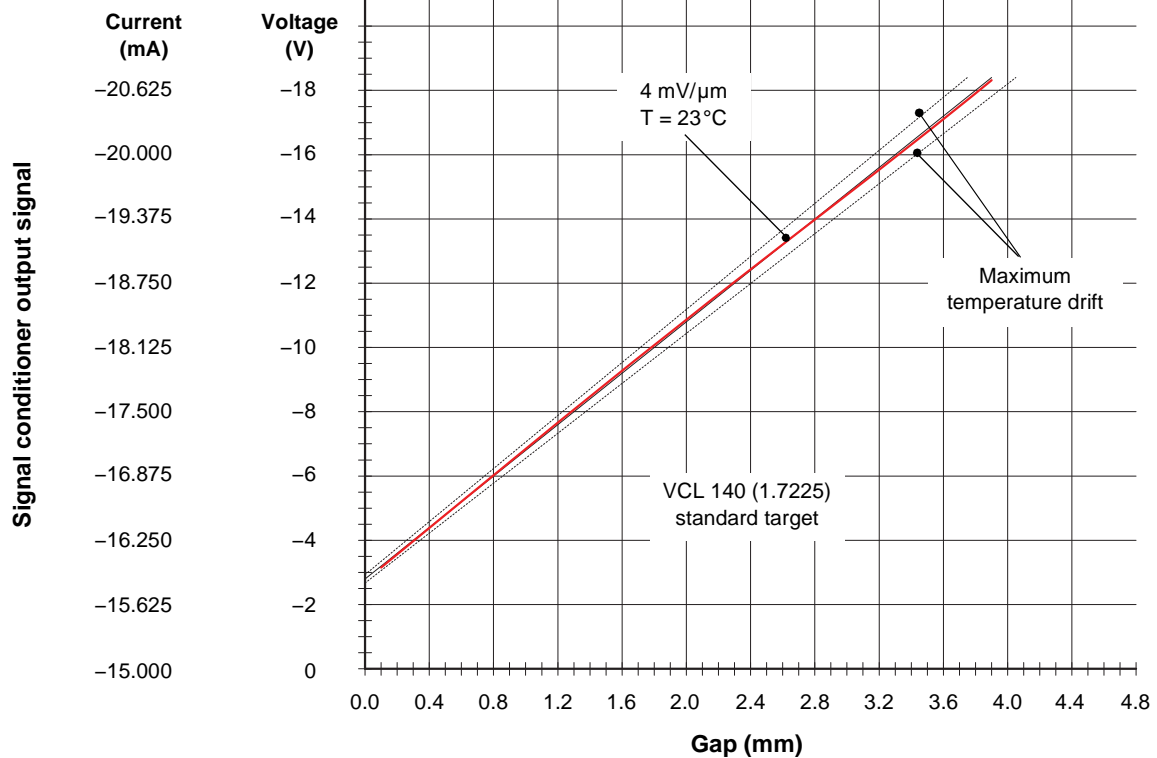

Proximity transducer: TQ 422 / TQ 432
Signal conditioner: IQS 450
Standard target material: VCL 140 (1.7225)
Equivalent materials: A 37.11 (1.0065), AFNOR 40 CD4, AISI 4140

SPECIFICATIONS *(continued)***TQ 422 and TQ 432 proximity transducers and EA 402 extension cable****General**

Transducer input requirements : High-frequency power source from an IQS 450 signal conditioner

Environmental

Temperature ranges

- *Transducer* : -25 to +140°C with drift < 5%
- *Transducer and cable* : **-40 to +195°C if used in an Ex Zone**
- *Cable and connector* : -40 to +200°C

Maximum pressures

- *Transducer tip* : 100 bar (TQ 422 and TQ 432)
- *Transducer/cable assembly* : 10 bar (with flexible hose option).
1 bar (without flexible hose option).

Protection rating (according to IEC 60529) : The head of the proximity transducer (transducer tip and integral cable) is rated IP68

Vibration (according to IEC 60068-2-26) : 5 g peak between 10 and 500 Hz

Shock acceleration (according to IEC 60068-2-27) : 15 g peak (half sine-wave, 11 ms duration)

Physical characteristics

Transducer construction : Wire coil Ø8 mm, PEEK (polyetheretherketone) tip, encapsulated in stainless steel body (1.4435) with high-temperature epoxy glue

Integral and extension cables : FEP covered 70 Ω coaxial cable, Ø3.6 mm

Connectors : Self-locking miniature coaxial connectors.
Note: When connecting, these should be hand-tightened until locked.

Optional protection

- *Flexible stainless steel hose (protection tube)* : The stainless steel hose of the TQ 422 and TQ 432 provides additional mechanical protection and is leak-tight.
The stainless steel hose of the EA 402 provides additional mechanical protection but is not leak-tight.
- *FEP sheath (extruded fluorinated ethylene propylene)* : The FEP sheath of the EA 402 provides resistance to almost all chemicals and low permeability to liquids, gases and moisture. It is also flexible, low friction and mechanically tough.

SPECIFICATIONS (continued)

IQS 450 signal conditioner

Output

Voltage output, 3-wire configuration

- *Voltage at min. gap* : -2.4 V
- *Voltage at max. gap* : -18.4 V
- *Dynamic range* : 16 V
- *Output impedance* : 500 Ω
- *Short-circuit current* : 45 mA

Current output, 2-wire configuration

- *Current at min. gap* : -15.5 mA
- *Current at max. gap* : -20.5 mA
- *Dynamic range* : 5 mA

Output capacitance : 1 nF

Output inductance : 100 μH

Supply

Voltage output, 3-wire configuration

- *Voltage* : -20 to -32 V*
- *Current* : -13 mA ± 1 mA (-25 mA max.)

Current output, 2-wire configuration

- *Voltage* : -20 to -32 V*
- *Current* : -15.5 to -20.5 mA

Supply input capacitance : 1 nF

Supply input inductance : 100 μH

Environmental

Temperature ranges

- *Operating* : -35 to +85 °C*
- *Storage* : -40 to +85 °C

Humidity : Max. 95% non condensing.
100% condensing (not submerged).

Protection rating : IP40
(according to IEC 60529)

Vibration : 2 g peak between 10 and 55 Hz
(according to IEC 60068-2-26)

Shock acceleration : 15 g peak (half sine-wave, 11 ms duration)
(according to IEC 60068-2-27)

Physical characteristics

Construction material : Injection moulded aluminium

Mounting : Two or four M4 screws

Dimensions : See Mechanical drawings and ordering information on page 11

*See Thermal considerations on page 7.

SPECIFICATIONS *(continued)*

Electrical connections

- Input : Self-locking miniature coaxial connector (female).
Note: When connecting, this should be hand-tightened, until locked.
- Output and power : Three screw terminals – wire section 2.5 mm² (max.)

Weight

- Standard version : 140 g (approx.)
Ex version : 220 g (approx.)

Signal conditioner with MA 130 mounting adaptor (ordering option I1)

- Universal DIN rail holder type : TSH 35
DIN rail type : TH 35-7.5 or TH 35-15
(according to EN 50022 / IEC 60715)

Thermal considerations

The IQS 450 signal conditioner will operate at ambient temperatures as high as 85°C, but to do so, it requires derating of the maximum input voltage. The IQS 450 must operate between the minimum supply voltage and the maximum supply voltage, as shown on the following graph.

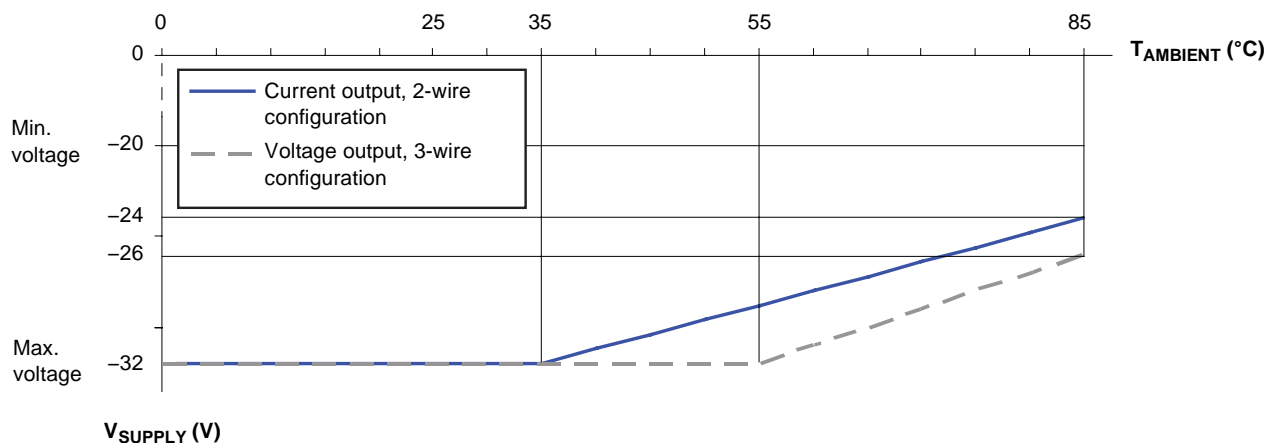

MECHANICAL DRAWINGS AND ORDERING INFORMATION

TQ 422 proximity transducer

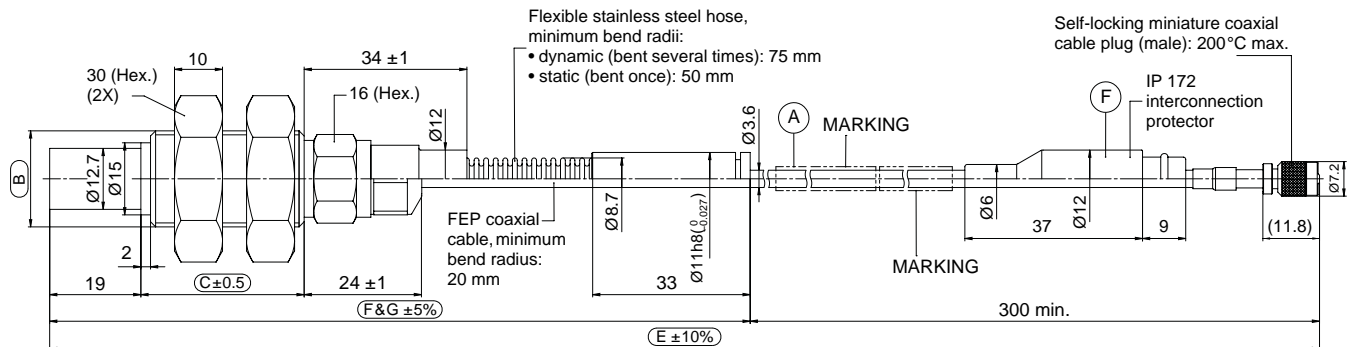

Ordering number:

111 - 422 - 000 - 013

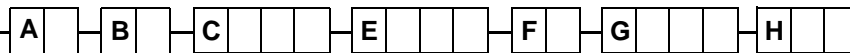

| Environment (A) | |
|-----------------|---|
| Standard | 1 |
| Explosive Ex i | 2 |
| Explosive Ex nA | 3 |

| Body thread (B) | |
|-----------------|---|
| M20 x 1.5 | 1 |

| Body length (C) | |
|-----------------|-----|
| 42 mm | 042 |
| 72 mm | 072 |
| 92 mm | 092 |
| 120 mm | 120 |
| 150 mm | 150 |
| 180 mm | 180 |

| Integral cable length (E) | |
|---------------------------|-----|
| 1 m | 010 |
| 5 m | 050 |
| 10 m | 100 |

| Optional protection (F) | | |
|-------------------------|---------------|-----------|
| | Cable | Connector |
| 0 | None | None |
| 1 | Flexible hose | None |
| 5 | None | IP 172 |
| 6 | Flexible hose | IP 172 |

| Total system length (H) | |
|-------------------------|------|
| See note 1 | |
| 01 | 1 m |
| 05 | 5 m |
| 10 | 10 m |

| Flexible hose length (G) | |
|--------------------------|--------------|
| 000 | None |
| 010 | 1 m nominal |
| 050 | 5 m nominal |
| 100 | 10 m nominal |

Notes

All dimensions are in mm unless otherwise stated.

1. The Total system length (H) = Integral cable length (E) + EA 402 extension cable length.

For information on combining integral and extension cables to obtain a particular total system length, see Total system length on page 3.

For information on cable length tolerances, see Total system length trimming on page 3.

MECHANICAL DRAWINGS AND ORDERING INFORMATION (continued)

TQ 432 proximity transducer

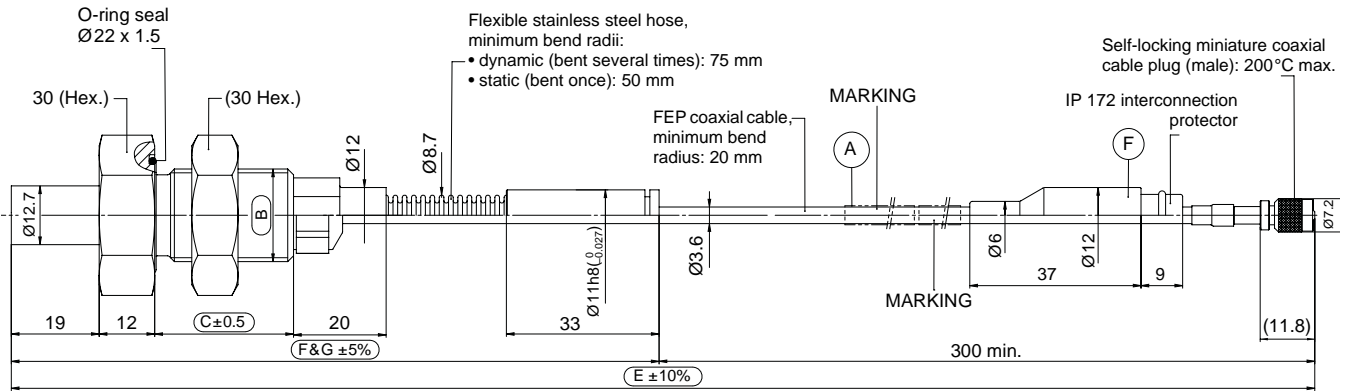

Ordering number:

111 - 432 - 000 - 013 - A - B - C - E - F - G - H

| Environment (A) | |
|-----------------|---|
| Standard | 1 |
| Explosive Ex i | 2 |
| Explosive Ex nA | 3 |

| Body thread (B) | |
|-----------------|---|
| M20 x 1.5 | 1 |

| Body length (C) | |
|-----------------|-----|
| 42 mm | 042 |

| Integral cable length (E) | |
|---------------------------|-----|
| 1 m | 010 |
| 5 m | 050 |
| 10 m | 100 |

| Total system length (H) | |
|-------------------------|------|
| See note 1 | |
| 01 | 1 m |
| 05 | 5 m |
| 10 | 10 m |

| Flexible hose length (G) | |
|--------------------------|--------------|
| 000 | None |
| 010 | 1 m nominal |
| 050 | 5 m nominal |
| 100 | 10 m nominal |

| Optional protection (F) | | |
|-------------------------|---------------|-----------|
| | Cable | Connector |
| 0 | None | None |
| 1 | Flexible hose | None |
| 5 | None | IP 172 |
| 6 | Flexible hose | IP 172 |

Notes

All dimensions are in mm unless otherwise stated.

1. The Total system length (H) = Integral cable length (E) + EA 402 extension cable length.

For information on combining integral and extension cables to obtain a particular total system length, see Total system length on page 3.

For information on cable length tolerances, see Total system length trimming on page 3.

MECHANICAL DRAWINGS AND ORDERING INFORMATION (continued)

EA 402 extension cable

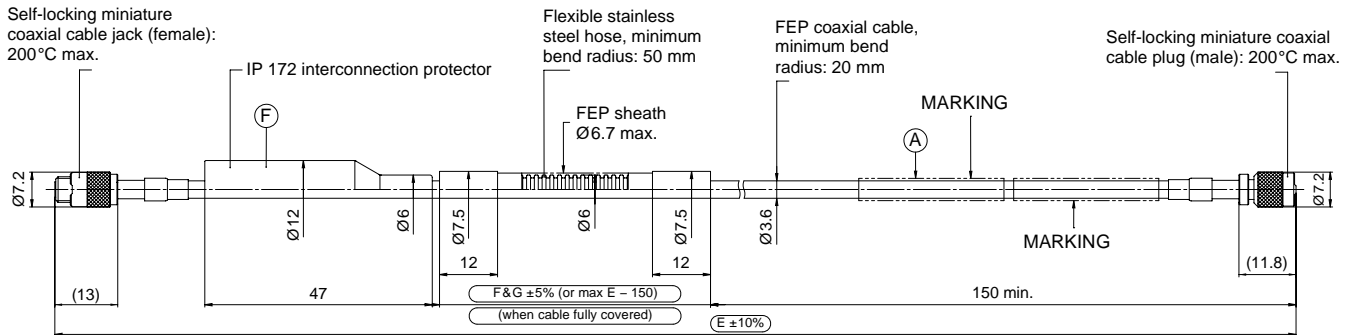

Ordering number: 913 - 402 - 000 - 013



| Environment (A) | |
|-----------------|---|
| Standard | 1 |
| Explosive Ex i | 2 |
| Explosive Ex nA | 3 |

| Extension cable length (E) See note 1 | |
|--|-----|
| 4.0 m ±400 mm | 040 |
| 5.0 m ±500 mm | 050 |
| 9.0 m ±900 mm | 090 |

| Optional protection (F) See note 2 | | |
|---------------------------------------|-----------|---|
| Cable | Connector | |
| None | None | 0 |
| Flexible hose | None | 1 |
| Flexible hose with FEP sheath | None | 2 |
| None | IP 172 | 5 |
| Flexible hose | IP 172 | 6 |
| Flexible hose with FEP sheath | IP 172 | 7 |

| Flexible hose length (G) | |
|-----------------------------|------------|
| Each 0.1 m, from 0 to 8.8 m | |
| 000 | None |
| 001 | 0.1 m min. |
| 088 | 8.8 m max. |

Notes

All dimensions are in mm unless otherwise stated.

1. The total system length = TQ 422/432 integral cable length + Extension cable length (E).

For information on combining integral and extension cables to obtain a particular total system length, see Total system length on page 3.

For information on cable length tolerances, see Total system length trimming on page 3.

2. When optional protection such as a flexible stainless steel hose with or without an FEP sheath is ordered:

Flexible hose length (G) max. = Extension cable length (E) - 150 mm, for an extension cable that is protected to the maximum extent possible ("cable fully covered").

MECHANICAL DRAWINGS AND ORDERING INFORMATION (continued)

IQS 450 signal conditioner

**Signal conditioner only
(ordering option I0)**

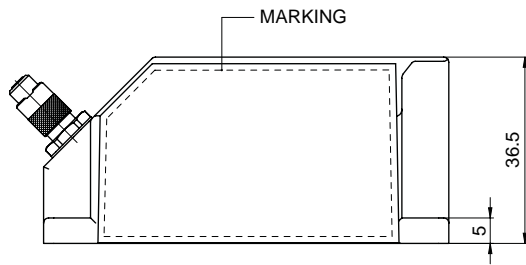

**Signal conditioner
with MA 130 mounting adaptor
(ordering option I1)**

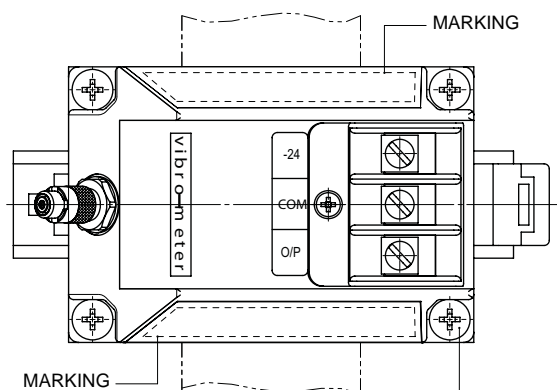
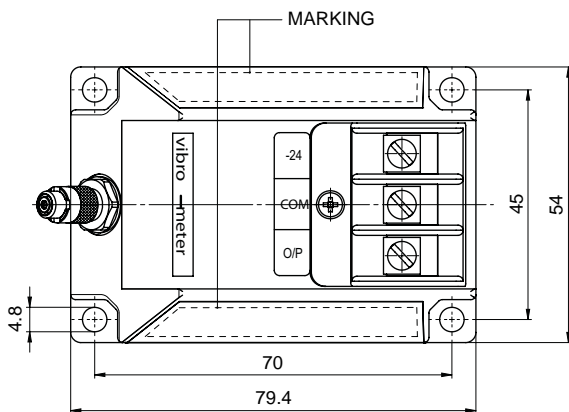
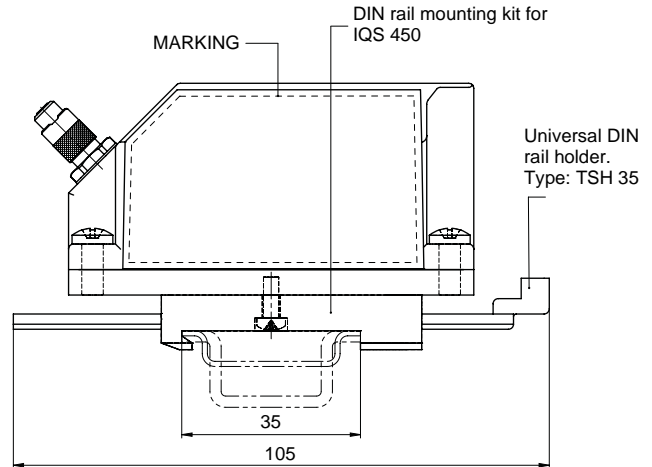

Note: All dimensions are in mm unless otherwise stated.

Self-tapping cross-recess screws.
Type: WN 1411, KA40 x 10.
Mounting torque: 0.4 N•m.

Ordering number: 204 - 450 - 000 - 002 - **A** - **B** - **H** - **I**

| Environment (A) | |
|-----------------|---|
| Standard | 1 |
| Explosive Ex i | 2 |
| Explosive Ex nA | 3 |

| Installation (I) | |
|------------------|---|
| 0 | Signal conditioner only |
| 1 | Signal conditioner assembled on MA 130 mounting adaptor |

| Measuring range | Sensitivity (B) | |
|-----------------|-----------------|---------|
| | 2 mm | 8 mV/μm |
| | 2.5 μA/μm | 22 |
| 4 mm | 4 mV/μm | 23 |
| | 1.25 μA/μm | 24 |

| Total system length (H) | |
|-------------------------|------|
| 01 | 1 m |
| 05 | 5 m |
| 10 | 10 m |

MOUNTING ACCESSORIES

| | | |
|---------|----------------------------|--------------------------------------|
| ABA 15x | Industrial housings | : Refer to corresponding data sheets |
| ABA 17x | Industrial housings | : Refer to corresponding data sheets |
| IP 172 | Interconnection protection | : Refer to corresponding data sheet |
| JB 118 | Junction box | : Refer to corresponding data sheet |
| KS 107 | Flexible conduit | : Refer to corresponding data sheet |
| MA 130 | Mounting adaptor | : See below |
| SG 1xx | Cable feedthroughs | : Refer to corresponding data sheets |

MA 130 mounting adaptor

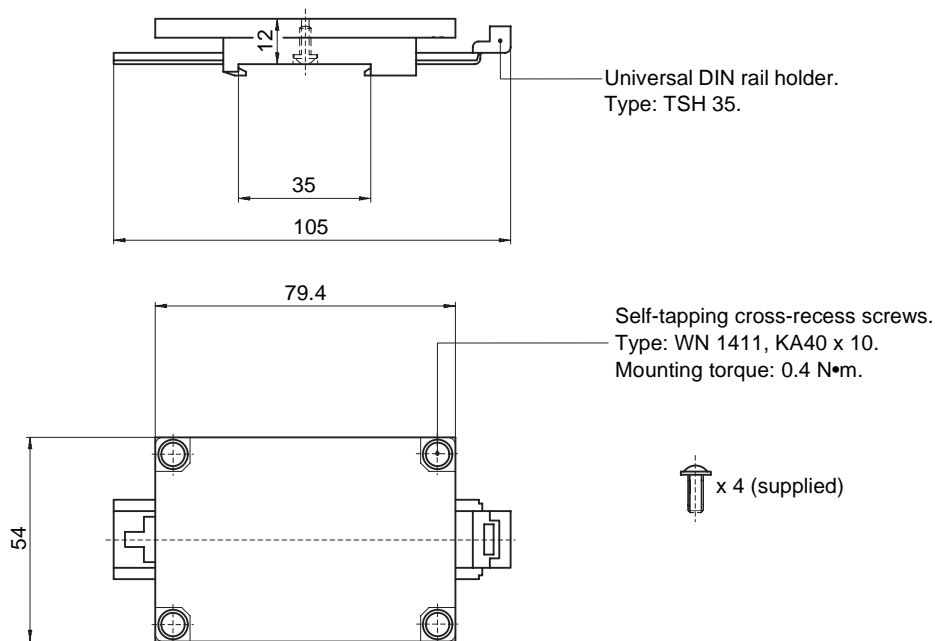

Note: All dimensions are in mm unless otherwise stated.

Ordering number: 809-130-000-011

Headquartered in the UK, Meggitt PLC is a global engineering group specializing in extreme environment components and smart sub-systems for aerospace, defence and energy markets.

Meggitt Sensing Systems is the operating division of Meggitt specializing in sensing and monitoring systems, which has operated through its antecedents since 1927 under the names of ECET, Endevco, Ferroperm Piezoceramics, Lodge Ignition, Sensorex, Vibro-Meter and Wilcoxon Research. Today, these operations are integrated under one strategic business unit called Meggitt Sensing Systems, headquartered in Switzerland and providing complete systems, using these renowned brands, from a single supply base.

The Meggitt Sensing Systems facility in Fribourg, Switzerland was formerly known as Vibro-Meter SA, but is now Meggitt SA. This site produces a wide range of vibration and dynamic pressure sensors capable of operation in extreme environments, leading-edge microwave sensors, electronics monitoring systems and innovative software for aerospace and land-based turbo-machinery.



All statements, technical information, drawings, performance rates and descriptions in this document, whilst stated in good faith, are issued for the sole purpose of giving an approximate indication of the products described in them, and are not binding on Meggitt SA unless expressly agreed in writing. Before acquiring this product, you must evaluate it and determine if it is suitable for your intended application. Unless otherwise expressly agreed in writing with Meggitt SA, you assume all risks and liability associated with its use. Any recommendations and advice given without charge, whilst given in good faith, are not binding on Meggitt SA.

Meggitt Sensing Systems takes no responsibility for any statements related to the product which are not contained in a current Meggitt Sensing Systems publication, nor for any statements contained in extracts, summaries, translations or any other documents not authored by Meggitt Sensing Systems. We reserve the right to alter any part of this publication without prior notice.

In this publication, a dot (.) is used as the decimal separator and thousands are separated by thin spaces. Example: 12345.67890.

Sales offices

Meggitt Sensing Systems has offices in more than 30 countries. For a complete list, please visit our website.



ISO 9001
FS 584089



Your local agent

Head office

Meggitt SA
Route de Moncor 4
PO Box 1616
CH - 1701 Fribourg
Switzerland

Tel: +41 26 407 11 11
Fax: +41 26 407 13 01

www.meggittsensingssystem.com
www.vibro-meter.com